

90° Long Radius Elbow

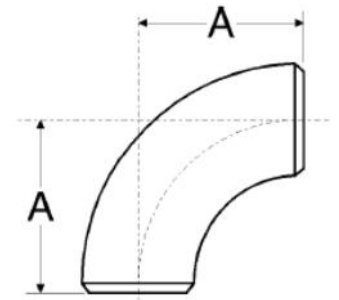

ASTM A403 / ANSI B16.9

Part Number	Nominal Pipe Size	Schedule	Dimensions (mm)			Weight Kg/Pce
			O.D	Wall Thickness	A	
015BWE90S106	½"	10s	21.3	2.11	38.1	0.06
020BWE90S106	¾"	10s	26.7	2.11	38.1	0.09
025BWE90S106	1"	10s	33.4	2.77	38.1	0.14
032BWE90S106	1¼"	10s	42.2	2.77	47.6	0.23
040BWE90S106	1½"	10s	48.3	2.77	57.2	0.31
050BWE90S106	2"	10s	60.3	2.77	76.2	0.51
065BWE90S106	2½"	10s	73.0	3.05	95.3	0.85
080BWE90S106	3"	10s	88.9	3.05	114.3	1.22
100BWE90S106	4"	10s	114.3	3.05	152.4	2.15
125BWE90S106	5"	10s	141.3	3.40	190.5	3.63
150BWE90S106	6"	10s	168.3	3.40	228.6	4.54
200BWE90S106	8"	10s	219.1	3.76	304.8	10.66
250BWE90S106	10"	10s	273.1	4.19	381.0	19.50
300BWE90S106	12"	10s	323.9	4.57	190.5	27.22

*Grade 316/L

*Schedule 10s Wall Thickness

*Seamless Construction

*Dimensions are for guidance only – Please call to confirm if critical!