

## ANSI B16.5 150LB RFWN SCH40S

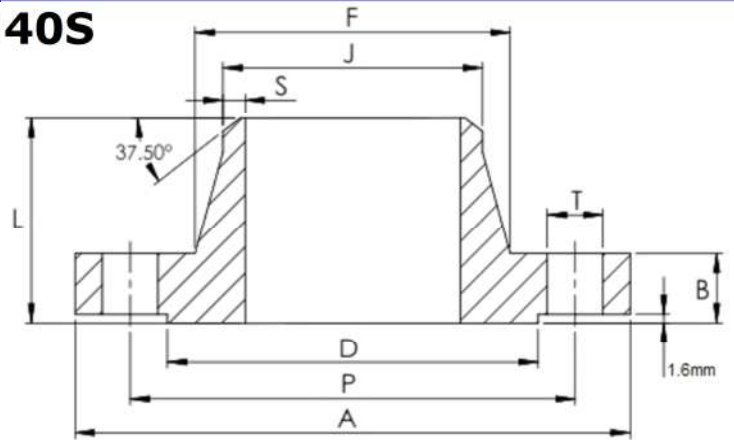

### #Number of Bolt Holes

Part Number	Size	A	B	D	L	F	J	S	P	T	#	Kg (Pc)
015FWN40316L	1/2"	89	11.1	35	48	30	21.3	2.77	60.3	15.9	4	0.59
020FWN40316L	3/4"	98	12.7	43	52	38	26.7	2.87	69.8	15.9	4	0.85
025FWN40316L	1"	108	14.3	51	56	49	33.4	3.38	79.4	15.9	4	1.10
032FWN40316L	1 1/4"	117	15.9	64	57	59	42.2	3.56	88.9	15.9	4	1.51
040FWN40316L	1 1/2"	127	17.5	73	62	65	48.3	3.69	98.4	15.9	4	1.96
050FWN40316L	2"	152	19.0	92	64	78	60.3	3.91	120.6	19.0	4	2.72
065FWN40316L	2 1/2"	178	22.2	105	70	90	73.0	5.16	139.7	19.0	4	4.41
080FWN40316L	3"	190	23.8	127	70	108	88.9	5.49	152.4	19.0	4	5.16
100FWN40316L	4"	229	23.8	157	76	135	114.3	6.02	190.5	19.0	8	7.25
125FWN40316L	5"	254	23.8	186	89	164	141.3	6.55	215.9	22.2	8	8.83
150FWN40316L	6"	279	25.4	216	89	192	168.3	7.11	241.3	22.2	8	11.06
200FWN40316L	8"	343	28.6	270	102	246	219.1	8.18	298.4	22.2	8	18.05
250FWN40316L	10"	406	30.2	324	102	305	273.0	9.27	362.0	25.4	12	23.84
300FWN40316L	12"	483	31.8	381	114	365	323.9	9.53	431.8	25.4	12	36.91
350FWN40316L	14"	533	34.9	413	127	400	355.6	9.53	476.2	28.6	12	50.15
400FWN40316L	16"	597	36.5	470	127	457	406.4	9.53	539.8	28.6	16	64.25
450FWN40316L	18"	635	39.7	533	140	505	457.2	9.53	577.8	31.8	16	69.74
500FWN40316L	20"	698	42.9	584	144	559	508.0	9.53	635.0	31.8	20	83.45
600FWN40316L	24"	813	47.6	692	152	664	609.6	9.53	749.4	34.9	20	120.5

\*Grade 316/L

\*RWN = Raised Faced Weld Neck

\*Surface Finish on Raised Face = Ra 3.2-6.3 µm

\*Dimensions in MM

\*Dimensions are for guidance only – Please call to confirm if critical!